



# HIGH BRIGHT LED FLASHING LIGHT

## 高亮度LED閃光警示燈

### HIGH BRIGHT LED FLASHING LIGHT

### 高亮度 LED 閃光警示燈

型式 MODEL	電壓 VOLTAGE	消耗功率 POWER	閃光次數 FLASHING-RATE	重量 WEIGHT	備註 REMARKS
DB-1224	12-24VDC	12W.	1.Single Flash:80FPM 2.Double Flash:85FPM	0.8kgs	WITH BOLT BASE
DB-1122	100-260VAC 50-60Hz		3.Tri-Flash:85FPM 4.Multi-Flash:75FPM	0.9kgs	
DB-1224M	12-24VDC		5.Rotating:95FPM 6.Cycle Flash	1.7kgs	WITH MAGNET BASE AND PLUG

〈附註〉DB-1224M底座附強力磁鐵及點菸器插頭

IP 67



#### 主要特長

- 高亮度LED，光度特亮，閃光頻率穩定。
- 創新折條紋燈罩，可將光線完美折射，任何角度均能發揮高度警示效果。
- 燈罩有紅、黃、藍三種顏色，採用耐衝擊PC材質，全天候風吹、雨淋、日曬均不變質。
- 底座附強力磁鐵，可強吸車頂，高速行駛也不脫落。
- 附4公尺彈簧電源線及點菸器插頭。

#### LED FLASHING LIGHT

1. The lights with high bright LED and steady flashing frequency.
2. Dome: with effective refractive design. To enlarge the light source to achieve better effects of warning.
3. Material of dome and base is polycarbonate with compact and water-proof. Colors available in red, yellow and blue.
4. DB-1224M: with magnetic base. To be suitable at high-speed when driving vehicles.
5. The light with 4M spiral line and plug.
6. 2-year warranty.



#### DB 尺寸圖

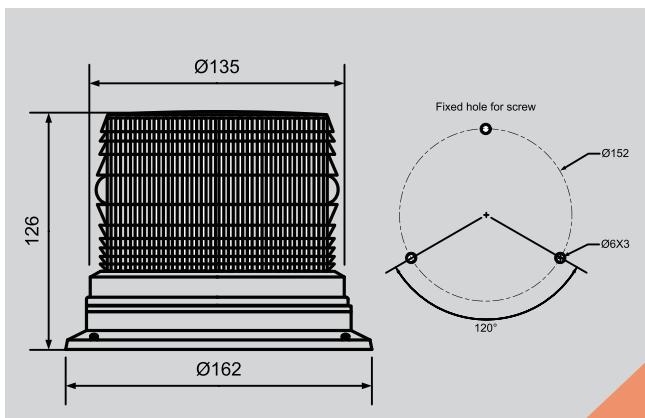

#### DB-M 尺寸圖

